

MINISTER OF EDUCATION
AND TRAINING

VIETNAM ACADEMY OF
SCIENCE AND TECHNOLOGY

GRADUATE UNIVERSITY OF SCIENCE AND TECHNOLOGY

Nguyen Thi Thuy Linh

**RESEARCH ON CHEMICAL CONSTITUENTS AND
BIOLOGICAL ACTIVITIES OF TWO SPECIES
IMPATIENS CHAPAENSIS AND
*IMPATIENS PARVISEPALA***

Major: Organic Chemistry

Code: 9 44 01 14

SUMMARY OF CHEMISTRY DOCTORAL THESIS

Ha Noi - 2023

The work was completed at: Graduate University of Science and Technology - Vietnam Academy of Science and Technology

Science instructor 1: Assoc. Prof. Dr. Nguyen Thi Hoang Anh

Science instructor 2: Assoc. Prof. Dr. Trinh Thi Thuy

Reviewer 1: Assoc. Prof. Dr. Pham Huu Dien

Reviewer 2: Assoc. Prof. Dr. Phan Minh Giang

Reviewer 3: Assoc. Prof. Dr. Nguyen Thi Hong Van

The thesis will be defended before the Doctoral Thesis Assessment Committee, meeting at the Graduate University of Science and Technology - Vietnam Academy of Science and Technology on, date/...../2023

The thesis can be found at:

- Library of Graduate University of Science and Technology
- National Library of Vietnam

PREFACE

1. The urgency of the thesis

Vietnamese traditional medicine has owned thousands of year's history, and national medicine has also continuously developed over those periods. Many herbal remedies with good clinical effects have not been studied thoroughly for their chemical compositions, pharmacological effects, as well as toxicity. Thus, research to exploit, inherit, apply, and develop plant resources for medicinal purposes has been and will be a matter of great scientific, economic, and social significance in our country.

The development of modern science gives us the chance to further analyze medicinal herbs, chemical components, and pharmacological effects through experimental studies. Many reports were annually published in domestic and foreign scientific journals across isolating biological compounds from different plant species, which serve as the scientific basis for the use of folk remedies in treatment effectively, as well as to promote the development of the medicinal and pharmaceutical fields in healthy improving and serving people's life.

Impatiens species (Balsaminaceae family) were known in folk medicine for the treatment of various diseases related to inflammation and diabetes in many parts of the world. The results of chemical and biological studies of these plants showed a large number of new secondary metabolites with interesting structures exhibiting valuable biological activities such as anti-inflammatory, hypoglycemic, anti-cancer, antioxidant, ... However, there are no reports on *Impatiens* species growing in Vietnam in spite of the fact that these herbs have been widely used for the treatment of various diseases in Vietnamese folk medicine.

Based on above-mentioned scientific basis, we chose the topic "Research on chemical constituents and biological activities of two species *Impatiens chapaensis* and *Impatiens parvisepala*".

2. Research aims of the thesis

- To study the chemical constituents of two *Impatiens* species, including: Moc tai Sapa (*Impatiens chapaensis*) and Bong nuoc dai hoa nho (*Impatiens parvisepala*).

- To search for the anti-inflammatory and hypoglycemic compounds from these two species.

3. Research content of the thesis

- To study the isolation of compounds from two *Impatiens* species: *I. chapaensis* and *I. parvisepala*;
 - To study the structure determination of isolated compounds;
 - To evaluate the anti-inflammatory activity (via NO inhibition effect) of isolated compounds;
 - To evaluate the hypoglycemic activity (via α -glucosidase inhibition effect) of isolated compounds.

CHAPTER 1. OVERVIEW

The overview summarized the domestic and foreign studies on the following problems:

1.1. Overview of the *Impatiens* genus

*1.1.1. Botanical features of the *Impatiens* plants*

*1.1.2. Traditional medicinal use of the *Impatiens* plants*

*1.1.3. Overview of the chemical compositions of the *Impatiens* genus*

*1.1.4. Overview of the biological activities of the *Impatiens* genus*

1.2. Overview of two species: Moc tai Sapa (*Impatiens chapaensis*) and Bong nuoc dai hoa nho (*Impatiens parvisepala*)

*1.2.1. Moc tai Sapa (*Impatiens chapaensis*)*

*1.2.2. Bong nuoc dai hoa nho (*Impatiens parvisepala*)*

CHAPTER 2. RESEARCH MATERIALS AND METHODS

2.1. Plant samples

In the thesis, the materials used for study were two plant samples:

- ❖ Sample 1: The whole plant of *Impatiens chapaensis* Tard. was collected in Hoanglien national park, Sapa district, Laocai province, Vietnam in October 2019. A voucher specimen VHH.SP 10.2019.1 was deposited in the Institute of Chemistry, VAST, Hanoi, Vietnam.
- ❖ Sample 2: The whole plant of *Impatiens parvisepala* S. X. Yu & Y. T. Hou was collected in Phia Oac-Phia Den national park, Nguyenbinh district, Caobang province, Vietnam in May 2020. A voucher specimen

VHH.CB 05.2020.1 was deposited in the Institute of Chemistry, VAST, Hanoi, Vietnam.

The scientific name of all these two plants were identified by Assoc. Prof. Dr. Vu Tien Chinh, Vietnam National Museum of Nature, VAST, Hanoi, Vietnam.

2.2. Research methods

2.2.1. Extraction and isolation methods

- Extraction method: using the total extraction method, illustrated in [Figure 2.3](#) and [Figure 2.7](#).

- Isolation method: using column chromatographic method with different adsorbents like silica gel, sephadex LH-20, and RP-18 with suitable solvent systems ([Figure 2.4, 2.5, 2.6, 2.8, 2.9](#)).

2.2.2. Methods of structure determination

Chemical structures of isolated compounds were elucidated by combining modern spectroscopic methods such as one-dimensional (^1H - và ^{13}C -NMR), two-dimensional (HSQC, HMBC, COSY và NOESY) nuclear magnetic resonance spectroscopy, mass spectra (ESI-MS, HR-ESI-MS) and CD spectra.

2.2.3. Methods of biological evaluation

2.2.3.1. Anti-inflammatory activity

The anti-inflammatory activity was evaluated through the inhibitory effect of NO production of RAW 264.7 cells with the use of N^G -methyl- L-arginine acetate (L-NMMA) as positive compound. The results were determined based on the IC_{50} value.

2.2.3.2. Hypoglycemic activity

The hypoglycemic activity was evaluated through the α -glucosidase inhibitory effect using acarbose as a positive control. The results were determined based on the IC_{50} value.

2.3. Extraction and isolation of compounds from two investigated plants

2.3.1. *I. chapaensis*

2.3.1.1. Plant sample preparation and extraction

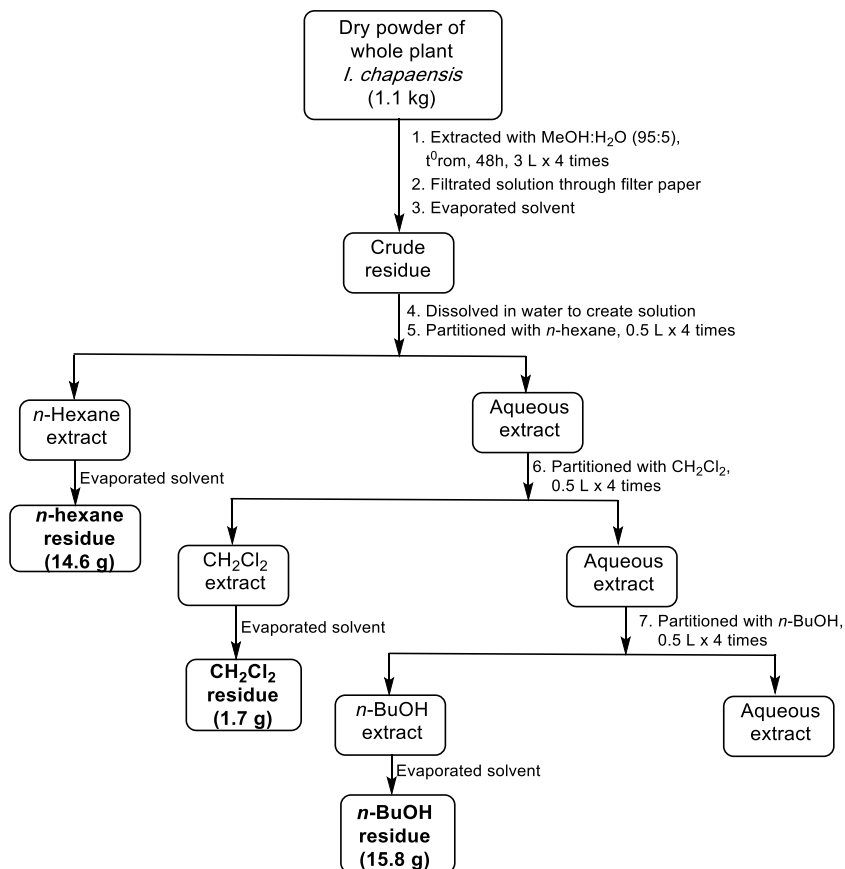
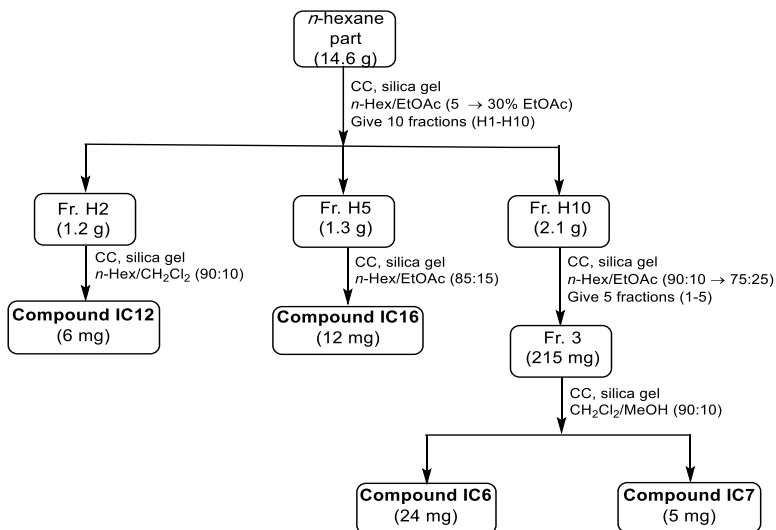

Figure 2.1. Plant sample preparation and extraction of *I. chapaensis*

2.3.1.2. Procedures of compound isolation

❖ Isolation of compounds from *n*-hexane extract:



Hình 2.2. Isolation of compounds from *n*-hexane extract of *I. chapaensis*

❖ Isolation of compounds from dichloromethane extract:

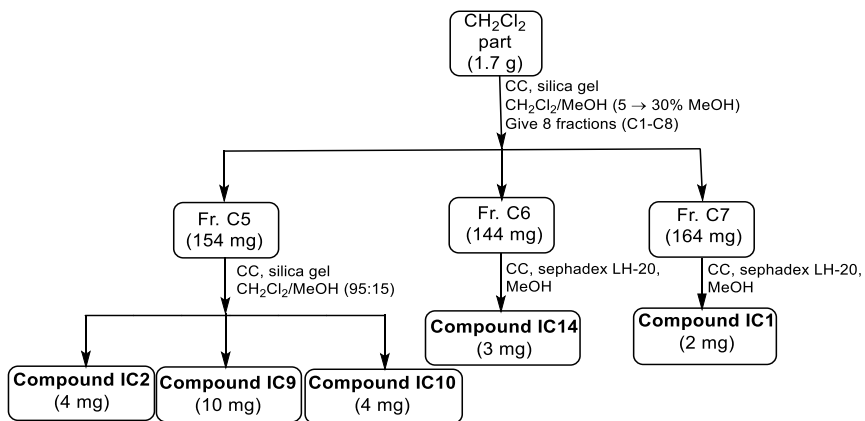

Hình 2.3. Isolation of compounds from CH_2Cl_2 extract of *I. chapaensis*

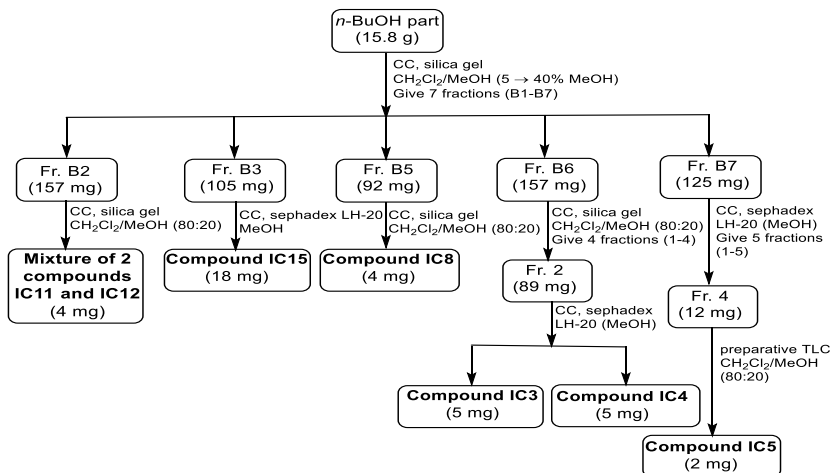
❖ Isolation of compounds from *n*-BuOH extract:**Hình 2.4.** Isolation of compounds from *n*-BuOH extract of *I. chapaensis*2.3.1.3. Spectroscopic data of compounds isolated from *I. chapaensis*

❖ Compound (*S*)-**naringenin (IC1)**: colorless gum, 2 mg (accounted for 0.00018% of the dry sample weight), $R_f = 0.5$ (*n*-hexane/EtOAc = 1/1), (–)-ESI-MS: m/z 271.8 [M-H][–], molecular formula C₁₅H₁₂O₅ (M = 272.0);

¹H-, ¹³C-NMR (500/125 MHz, CD₃OD) (Table 3.1).

❖ Compound (*S*)-**pinocembrin (IC2)**: yellow crystal, 4 mg (accounted for 0.00036% of the dry sample weight), $R_f = 0.5$ (*n*-hexane/EtOAc = 3/1), molecular formula C₁₅H₁₂O₄ (M = 256.0);

¹H-, ¹³C-NMR (500/125 MHz, CD₃OD) (Table 3.2).

❖ Compound **kaempferol (IC3)**: yellow powder, 5 mg (accounted for 0.00045% of the dry sample weight), $R_f = 0.45$ (CH₂Cl₂/MeOH = 95/5), molecular formula C₁₅H₁₀O₆ (M = 286.0);

¹H-, ¹³C-NMR (500/125 MHz, CD₃OD) (Table 3.3).

❖ Compound **quercetin (IC4)**: yellow powder, 5 mg (accounted for 0.00045% of the dry sample weight), $R_f = 0.35$ ($\text{CH}_2\text{Cl}_2/\text{MeOH} = 95/5$), molecular formula $\text{C}_{15}\text{H}_{10}\text{O}_7$ ($M = 302.0$);

^1H -, ^{13}C -NMR (500/125 MHz, CD_3OD) (Table 3.4).

❖ Compound (\pm)-**3',5',5',7-tetrahydroxyflavanone (IC5)**: yellow powder, 2 mg (accounted for 0.00018% of the dry sample weight), $R_f = 0.40$ ($\text{CH}_2\text{Cl}_2/\text{MeOH} = 95/5$), molecular formula $\text{C}_{15}\text{H}_{10}\text{O}_6$ ($M = 288.0$);

^1H -, ^{13}C -NMR (500/125 MHz, CD_3OD) (Table 3.5).

❖ Compound **phlorizin (IC6)**: yellow oil, 24 mg (accounted for 0.00218% of the dry sample weight), $R_f = 0.60$ ($\text{EtOAc}/\text{MeOH} = 4/1$), molecular formula $\text{C}_{21}\text{H}_{24}\text{O}_{10}$ ($M = 436.1$);

^1H -, ^{13}C -NMR (500/125 MHz, CD_3OD) (Table 3.6).

❖ Compound **2,4-dihydroxydihydrochalcone-6-O- β -D-glucopyranoside (IC7)**: yellow oil, 5 mg (accounted for 0.00045% of the dry sample weight), $R_f = 0.65$ ($\text{CH}_2\text{Cl}_2/\text{MeOH} = 6/1$), (-)-ESI-MS: m/z 418.9 $[\text{M}-\text{H}]^-$, molecular formula $\text{C}_{21}\text{H}_{24}\text{O}_9$ ($M = 420.1$);

^1H -, ^{13}C -NMR (500/125 MHz, CD_3OD) (Table 3.7).

❖ Compound **isoquercitrin (IC8)**: yellow solid, 4 mg (accounted for 0.00036% of the dry sample weight), $R_f = 0.50$ ($\text{EtOAc}/\text{MeOH} = 4/1$), molecular formula $\text{C}_{21}\text{H}_{20}\text{O}_{12}$ ($M = 464.1$);

^1H -, ^{13}C -NMR (500/125 MHz, CD_3OD) (Table 3.8).

❖ Compound **methyl 4-hydroxybenzoate (IC9)**: white solid, 10 mg (accounted for 0.00091% of the dry sample weight), $R_f = 0.35$ (n -hexan/ $\text{EtOAc} = 3/1$), molecular formula $\text{C}_8\text{H}_8\text{O}_3$ ($M = 152.2$);

^1H -, ^{13}C -NMR (500/125 MHz, CDCl_3) (Table 3.9).

❖ Compound **methyl 2,4,6-trihydroxybenzoate (IC10)**: yellow solid, 4 mg (accounted for 0.00036% of the dry sample weight), $R_f = 0.25$ (n -hexan/ $\text{EtOAc} = 3/1$), (+)-ESI-MS: m/z : 222.7 $[\text{M}+\text{K}]^+$, molecular formula $\text{C}_8\text{H}_8\text{O}_5$ ($M = 184.0$);

^1H -, ^{13}C -NMR (500/125 MHz, CDCl_3) (Table 3.10).

❖ Compound **isotachioside (IC11)**: white powder, 1.8 mg (accounted for 0.00016% of the dry sample weight), $R_f = 0.55$ (EtOAc/MeOH = 4/1), molecular formula $\text{C}_{13}\text{H}_{18}\text{O}_8$ ($M = 302.0$);

^1H -, ^{13}C -NMR (500/125 MHz, CD_3OD) (Table 3.11).

❖ Compound **uridine (IC12)**: white powder, 2.2 mg (accounted for 0.00020% of the dry sample weight), $R_f = 0.55$ (EtOAc/MeOH = 4/1), molecular formula $\text{C}_9\text{H}_{12}\text{N}_2\text{O}_6$ ($M = 244.1$);

^1H -, ^{13}C -NMR (500/125 MHz, CD_3OD) (Table 3.12).

❖ Compound **spinasterol (IC13)**: white powder, 6 mg (accounted for 0.00055% of the dry sample weight), $R_f = 0.50$ (*n*-hexane/EtOAc = 75/25), molecular formula $\text{C}_{29}\text{H}_{48}\text{O}$ ($M = 412.3$);

^1H -, ^{13}C -NMR (500/125 MHz, CDCl_3) (Table 3.13).

❖ Compound **isofraxidin (IC14)**: white solid, 3 mg (accounted for 0.00027% of the dry sample weight), $R_f = 0.50$ (*n*-hexane/acetone = 2/1), (+)-ESI-MS: m/z 222.8 $[\text{M}+\text{H}]^+$, molecular formula $\text{C}_{11}\text{H}_{10}\text{O}_5$ ($M = 222.0$);

^1H -, ^{13}C -NMR (500/125 MHz, CD_3OD) (Table 3.14).

❖ Compound **(7R,8S)-yemuoside YM1 (IC15)**: white powder, 18 mg (accounted for 0.00164% of the dry sample weight), $R_f = 0.60$ (EtOAc/MeOH = 4/1), (-)-ESI-MS: m/z 505 $[\text{M}-\text{H}]^-$, molecular formula $\text{C}_{25}\text{H}_{30}\text{O}_{11}$ ($M = 506.1$);

^1H -, ^{13}C -NMR (500/125 MHz, CD_3OD) (Table 3.15).

❖ Compound **(S)-dehydrovomifoliol (IC16)**: colorless oil, 12 mg (accounted for 0.00109% of the dry sample weight), $R_f = 0.25$ (*n*-hexane/EtOAc = 4/1), $[\alpha]_D^{25} = +135.8$ ($c = 0.1$, CH_3OH), (-)-ESI-MS: m/z : 220.7 $[\text{M}-\text{H}]^-$, molecular formula $\text{C}_{13}\text{H}_{18}\text{O}_3$ ($M = 222.0$);

^1H -, ^{13}C -NMR (500/125 MHz, CDCl_3) (Table 3.16).

2.3.2. *I. parvisepala*

2.3.2.1. Plant sample preparation and extraction

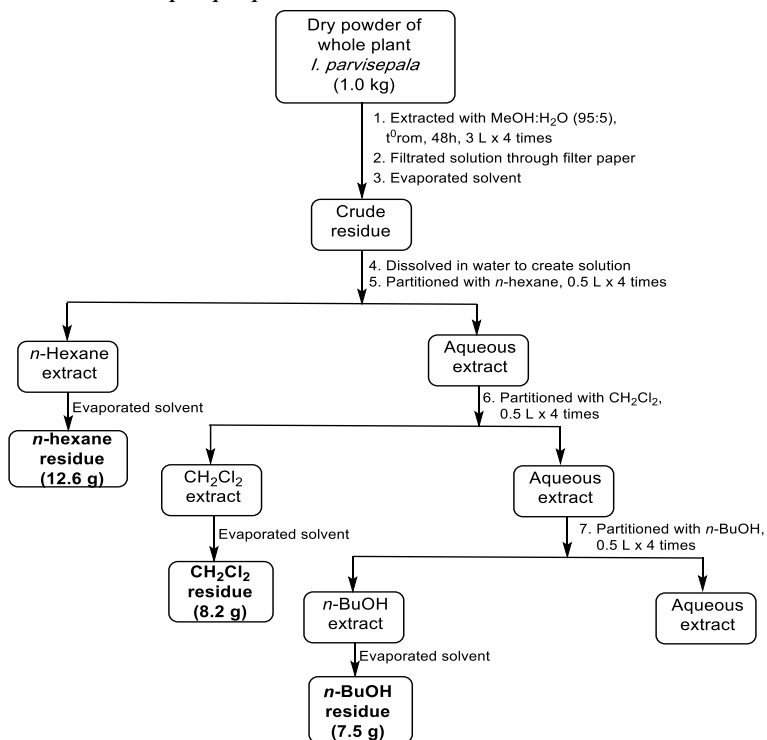

Hình 2.7. Plant sample preparation and extraction of *I. parvisepala*

2.3.2.2. Procedures of compound isolation

- ❖ Isolation of compounds from *n*-hexane extract:

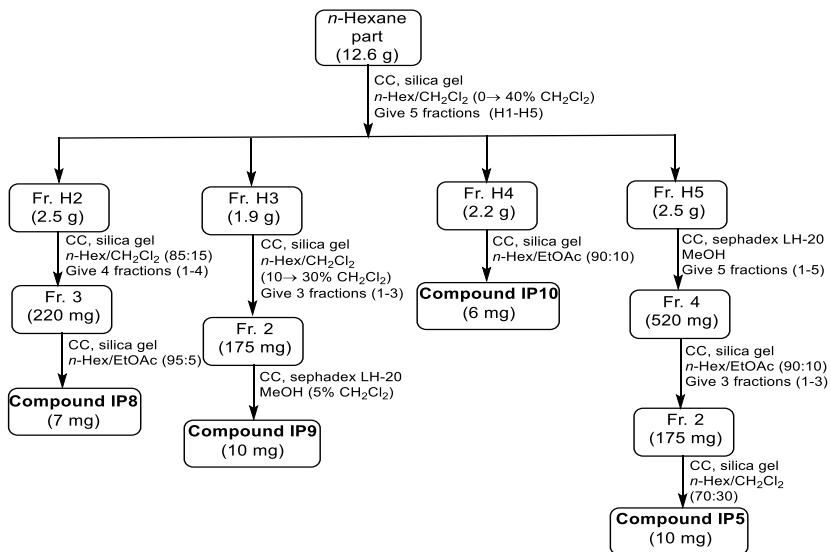

Hình 2.8. Isolation of compounds from *n*-hexane extract of *I. parvisepala*

❖ Isolation compounds from *n*-BuOH extract:

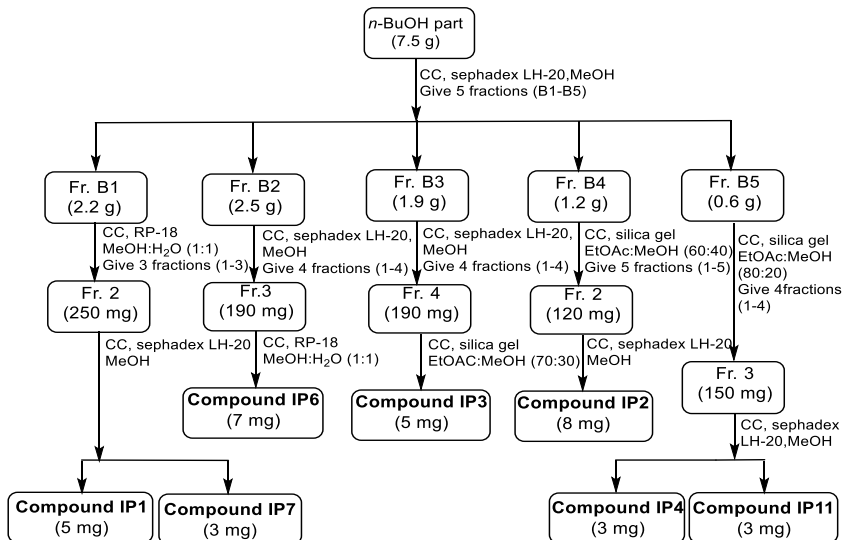

Figure 2.9. Isolation of compounds from *n*-BuOH extract of *I. parvisepala*

2.3.2.3. Spectroscopic data of compounds isolated from *I. parvisepala*

❖ Compound **kaempferol-3-O- α -L-rhamnopyranosyl-(1 \rightarrow 6)- β -D-glucopyranoside (IP1)**: yellow solid, 5 mg (accounted for 0.0005% of the dry sample weight), $R_f = 0.35$ (MeOH/H₂O = 1/1, reverse phase thin layer chromatography RP-18), (-)-ESI-MS: m/z 593.0 [M-H]⁻; (+)-ESI-MS: m/z 617.1 [M+Na]⁺, molecular formula C₂₇H₃₀O₁₅ (M = 594.0);

¹H-, ¹³C-NMR (600/150 MHz, CD₃OD) (Table 3.18).

❖ Compound **apigenin 7-O- β -D-glucopyranoside (IP2)**: yellow solid, 8 mg (accounted for 0.0008% of the dry sample weight), $R_f = 0.5$ (EtOAc/MeOH = 4/1), (-)-ESI-MS: m/z 430.9 [M-H]⁻, molecular formula C₂₁H₂₀O₁₀ (M = 432.1);

¹H-, ¹³C-NMR (600/150 MHz, CD₃OD) (Table 3.19).

❖ Compound **isoquercitrin (IP3)**: yellow powder, 4 mg (accounted for 0.0004% of the dry sample weight), $R_f = 0.5$ (EtOAc/MeOH = 6/4), (-)-ESI-MS: m/z 462.9 [M-H]⁻; (+)-ESI-MS: m/z 487.0 [M+Na]⁺, molecular formula C₂₁H₂₀O₁₀ (M = 464.1);

¹H-, ¹³C-NMR (600/150 MHz, CD₃OD) (Table 3.20).

❖ Compound **phlorizin (IP4)**: yellow oil, 3 mg (accounted for 0.0003% of the dry sample weight), $R_f = 0.6$ (EtOAc/MeOH = 4/1), (-)-ESI-MS: m/z 435.0 [M-H]⁻, molecular formula C₂₁H₂₄O₁₀ (M = 436.1);

¹H-, ¹³C-NMR (600/150 MHz, CD₃OD) (Table 3.21).

❖ Compound **lupeol (IP5)**: white solid, 10 mg (accounted for 0.0010% of the dry sample weight), $R_f = 0.40$ (*n*-hexane/EtOAc = 85/15, (+)-ESI-MS: m/z 427.2 [M+H]⁺, molecular formula C₃₀H₅₀O (M = 426.3);

¹H-, ¹³C-NMR (600 MHz, CD₃OD) (Table 3.22).

❖ Compound **ginsenoside Rg1 (IP6)**: colorless solid, 7 mg (accounted for 0.0007% of the dry sample weight), $R_f = 0.55$ (EtOAc/MeOH = 7/3, HR-ESI-MS: m/z 835.4609 [M-Cl]⁻ (calcd. for [C₄₂H₇₂O₁₄Cl]⁻, 835.4616), molecular formula C₄₂H₇₂O₁₄ (M = 800.5);

¹H-, ¹³C-NMR (600/150 MHz, pyridin-*d*₅) (Table 3.23)

❖ **New compound: 3-O-[[α -L-arabinopyranosyl-(1 \rightarrow 3)-]- β -D-glucopyranosyl-(1 \rightarrow 2)]- β -D-glucuronopyranoside 16 α -O-acetyl-3 β ,22 α ,28 β -trihydroxy-olean-12-ene (named *iparvisepala-1*) (IP7)**: white solid, 3 mg (accounted for 0.0003% of the dry sample weight), $R_f =$

0.50 (EtOAc/MeOH = 6/4, HR-ESI-MS: m/z 1021.4789 $[M+Cl]^-$ (calcd. for $[C_{49}H_{78}O_{20}Cl]^-$, 1021.4780), molecular formula $C_{49}H_{78}O_{20}$ ($M = 986.5$);

1H -, ^{13}C -NMR (600/150 MHz, CD_3OD) (Table 3.25).

❖ Compound **α -tocopherylquinone (IP8)**: yellow oil, 7 mg (accounted for 0.0007% of the dry sample weight), $R_f = 0.35$ (n -hexane/EtOAc = 85/15, molecular formula $C_{29}H_{50}O_3$ ($M = 446.3$);

1H -, ^{13}C -NMR (600/150 MHz, $CDCl_3$) (Table 3.26).

❖ Compound **phytol (IP9)**: yellow oil, 10 mg (accounted for 0.0010% of the dry sample weight), $R_f = 0.45$ (n -hexane/EtOAc = 85/15), (–)-ESI-MS: m/z 295.1 $[M-H]^-$, molecular formula $C_{20}H_{40}O$ ($M = 296.3$);

1H -, ^{13}C -NMR (600/150 MHz, $CDCl_3$) (Table 3.27).

❖ Compound **1-[nonadeca-(9Z,12Z)-dienoyl]-sn-glycerol (IP10)**: white solid, 6 mg (accounted for 0.0006% of the dry sample weight), $R_f = 0.35$ (n -hexane/acetone = 2/1), (–)-ESI-MS: m/z 367.1 $[M-H]^-$, molecular formula $C_{22}H_{40}O_4$ ($M = 368.3$);

1H -, ^{13}C -NMR (600/150 MHz, CD_3OD) (Table 3.28).

❖ Compound **uracil (IP11)**: colorless solid, 3 mg (accounted for 0.0003% of the dry sample weight), $R_f = 0.30$ (CH_2Cl_2 /MeOH = 9/1), (+)-ESI-MS: m/z 112.6 $[M+H]^+$, molecular formula $C_4H_4N_2O_2$ ($M = 112.0$);

1H NMR (600 MHz, CD_3OD , δ_H , ppm, J /Hz): 5.63 (d, $J = 7.5$ Hz, H-5), 7.41 (d, $J = 7.5$ Hz, H-6).

CHAPTER 3. RESULTS AND DISCUSSION

3.1. Analyzing, determining the structure of compounds isolated from *I. chapaensis*

The results on phytochemical study of this plant showed that, 16 compounds (**IC1 – IC16**) were isolated, which cover 8 flavonoids: (*S*)-naringenin (**IC1**), (*S*)-pinocembrin (**IC2**), kaempferol (**IC3**), quercetin (**IC4**), (\pm)-3',5',7-tetrahydroxyflavanone (**IC5**), phlorizin (**IC6**), 2,4-dihydroxydihydrochalcone-6-*O*- β -D-glucopyranoside (**IC7**), and isoquercitrin (**IC8**); 3 monophenols: methyl 4-hydroxybenzoate (**IC9**), methyl 2,4,6-trihydroxybenzoate (**IC10**), and isotachioside (**IC11**); and 5

miscellaneous: uridine (**IC12**), spinasterol (**IC13**), isofraxidin (**IC14**), (7*R*,8*S*)-yemuoside YM1 (**IC15**), and (*S*)-dehydrovomifoliol (**IC16**). Among these, 9 compounds (**IC1**, **IC5**, **IC6**, **IC7**, **IC10**, **IC11**, **IC12**, **IC15**, and **IC16**) were isolated for the first time from *Impatiens* genus.

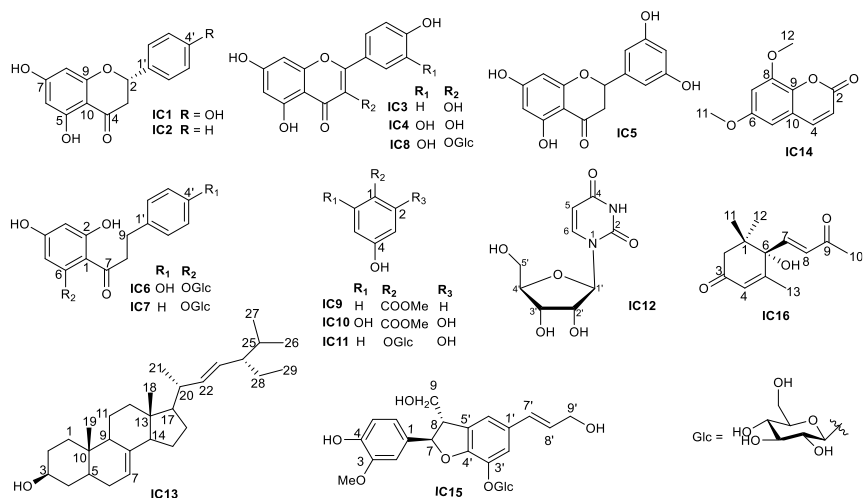

3.2. Analyzing, determining the structure of compounds isolated from *I. parvisepala*

The phytochemical analysis of this plant led to the isolation of 11 compounds (**IP1** – **IP11**), including 4 flavonoids: kaempferol-3-*O*- α -L-rhamnopyranosyl-(1 \rightarrow 6)- β -D-glucopyranoside (**IP1**), apigenin 7-*O*- β -D-glucopyranoside (**IP2**), isoquercitrin (**IP3**), and phlorizin (**IP4**); 3 triterpenoids: lupeol (**IP5**), ginsenoside Rg1 (**IP6**), and iparvisepala-1 (**IP7**); and 4 miscellaneous: α -tocopherylquinone (**IP8**), phytol (**IP9**), 1-[nonadeca-(9*Z*,12*Z*)-dienoyl]-*sn*-glycerol (**IP10**), and uracil (**IP11**). Among these, saponin **IP7** was found to be a new compound, while 7 compounds (**IP1**, **IP5**, **IP6** và **IP8** – **IP11**) were firstly isolated from *Impatiens* genus.

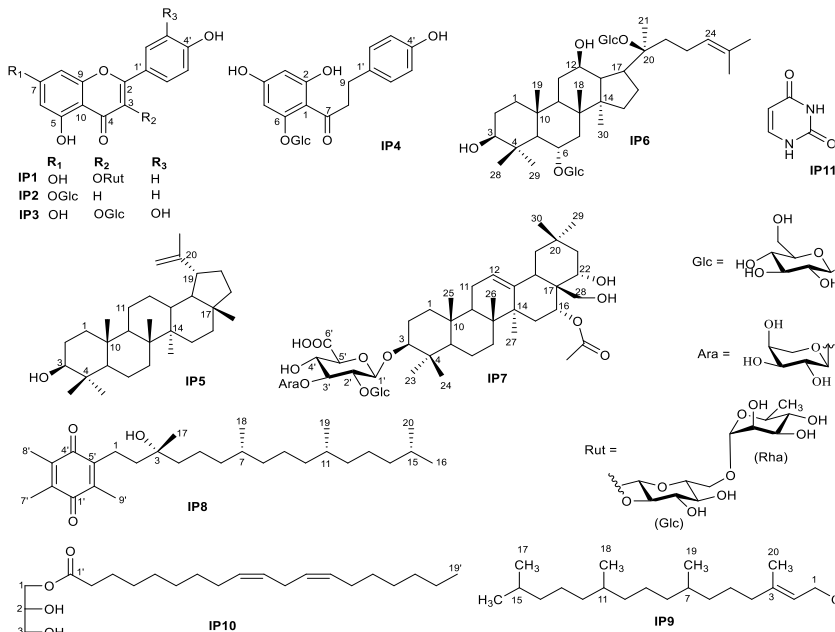

❖ **New compound: IP7**

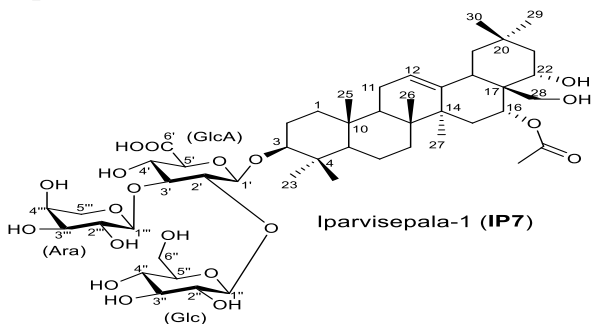

Compound **IP7** was obtained as white powder. It indicated a $[M+Cl]^-$ quasimolecular ion peak at m/z 1021.4701 (calcd. for $C_{49}H_{78}O_{20}Cl$ 1021.4775) in the negative HR-ESI-MS. The negative ion mode showed m/z 985.4992 $[M-H]^-$ ($C_{49}H_{77}O_{20}$), which was fragmented in MS/MS to yield peaks corresponding to the loss of one hexose unit at m/z 805.4418 $[(M-H)-180]^-$, to the subsequent loss of one pentose unit at m/z 655.3882 $[(M-H)-180-150]^-$, to the continuous loss of glucuronic acid at 515.3740

[(M-H)-180-150-140]⁻. From that, the molecular formula of **IP7** was determined as C₄₉H₇₈O₂₀. NMR spectra (Table 3.25) of this compound suggested it is a triterpenoid saponin, revealing typical signals of olean-12-ene at δ_{H} 5.37 t, 3.0 Hz (H-12) of double bond at δ_{C} 125.3 (C-12), 142.6 (C-13) and seven singlet methyls, which resonanced in the range of δ_{H} from 0.9 to 1.1; three oxygen-methine and one oxymethylene groups at δ_{H} 3.23 (d, $J = 4.2, 12.0$ Hz, H-3), 5.48 (m, H-16), 4.07 (dd, $J = 5.5, 12.0$ Hz, H-22), 3.30 (m, H-28a) and 3.60 (m, H-28b) correspond to 91.8 (C-3), 72.7 (C-16), 73.9 (C-22) và 69.8 (C-28), respectively. These suggestions were confirmed by the cross peaks between δ_{H} 5.48 (H-16)/1.95 (H₂-15); δ_{H} 4.07 (H-22)/1.48, 1.66 (H-21); δ_{H} 5.37 (H-12)/1.91 (H-11); δ_{H} 4.48 (H-1')/3.82 (H-2'); and δ_{H} 3.82 (H-2')/3.77 (H-3') in the COSY spectrum, as well as HMBC correlations between δ_{H} 4.07 (H-22)/ δ_{C} 72.7 (C-16); δ_{H} 3.30 and 3.60 (H-28)/ δ_{C} 72.7 (C-16), 44.4 (C-17), 42.5 (C-18) and 73.9 (C-22); and δ_{H} 3.62 (H-5')/ δ_{C} 176.1 (COOH) (Figure 3.56). The signals at δ_{H} 2.03, δ_{C} 22.2 and 171.8 as well as the downfield shift of H-16 (5.48 ppm) suggested the connection position of acetyl group at C-16. The configurations were determined as 3 β , 16 α , 22 α , 28 β due to observed cross peaks between δ_{H} 3.23 (H-3)/ 0.8 (H-5), 1.09 (H-23); δ_{H} 5.48 (H-16)/ 3.6 (H-28); δ_{H} 4.07 (H-22)/ 1.01 (H-30) in NOESY spectrum. The comparison of above spectral analysis with the published data led to conclude that aglycone part of **6** was 16 α -O-acetyl-3 β ,22 α ,28 β -trihydroxy-olean-12-ene (Grabowska et al. 2017). Corresponding to MS data, three anomeric groups at δ_{H} 4.48 (d, 7.8), δ_{C} 105.7; δ_{H} 4.98 (d, 7.8), δ_{C} 103.2 và δ_{H} 4.64 (d, 7.2), δ_{C} 104.7 confirmed the presence of three sugar units. The connection positions between glycon with aglycon moieties, as well as between glycon units were determined basing on HMBC correlations (Figure 3.56): between H-1 of glucuronopyranose (4.49 ppm) with C-3 (91.8); H-1' of glucopyranose (4.98 ppm) with C-2' of glucuronopyranose (78.8 ppm); H-1'' of arabinopyranose (4.64 ppm) with C-3' of glucuronopyranose (86.3 ppm). The sugar moiety of **IP7** was well accordant with those of saponin Pittangretoside G published in the literature.

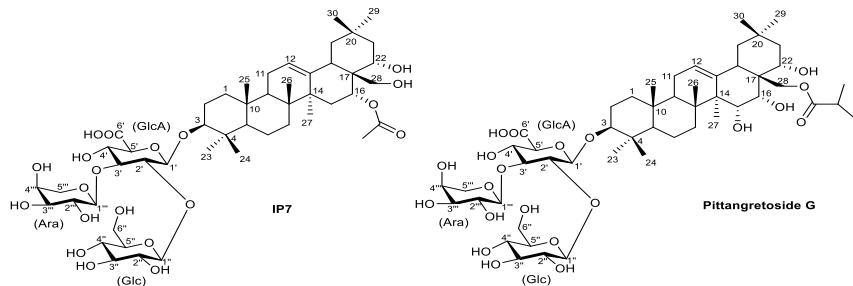

Hình 3.1. Structure of compounds **IP7** and pittangretoside **G**

Bảng 3.1. ^1H - and ^{13}C -NMR data of sugar moiety of compound **IP7** as compared to that of compound pittangretoside **G** published in literature

C	Compound IP7 (CD_3OD)		pittangretoside G (CD_3OD)	
	δ_{H}	δ_{C}	δ_{H}	δ_{C}
3-OGlcA			3-OGlcA	
1'	4.48 (d, $J = 7.8$ Hz)	105.7, CH	4.55 (d, $J = 7.5$ Hz)	104.8, CH
2'	3.82 (m)	78.8, CH	3.84	77.3, CH
3'	3.77 (t, $J = 8.4$)	86.3, CH	3.77	85.5, CH
4'	3.64 (m)	72.9, CH	3.65	71.5, CH
5'	3.62 (m)	78.3, CH	3.77	76.2, CH
6'	-	176.1, C	-	172.5
2'-OGlc			2'-OGlc	
1''	4.98 (d, $J = 7.8$ Hz)	103.2, CH	4.99 (d, $J = 7.5$ Hz)	102.0, CH
2''	3.19 (m)	76.2, CH	3.16 (t, $J = 8.0$ Hz)	75.4, CH
3''	3.37 (m)	78.2, CH	3.38 (t, $J = 8.0$ Hz)	77.2, CH
4''	3.10 (m)	72.6, CH	3.10 (t, $J = 9.0$ Hz)	71.7, CH
5''	3.37 (m)	78.2, CH	3.33	77.4, CH
6''	3.57 (dd, $J = 7.2$, 12.0 Hz) 3.84 (dd, $J = 1.8$, 10.2 Hz)	63.6, CH_2	3.59 3.85	62.6, CH_2
3'-OAra			3'- OAra	
1'''	4.64 (d, $J = 7.2$ Hz)	104.7, CH	4.61 (d, $J = 7.0$ Hz)	104.1, CH
2'''	3.62 (m)	72.1, CH	3.64	71.5, CH
3'''	3.57 (m)	74.6, CH	3.52	73.6, CH
4'''	3.80 (m)	70.1, CH	3.84	69.1, CH
5'''	3.94 (dd, $J = 2.4$, 12.6 Hz) 3.61 (m)	67.7, CH_2	3.94 3.63	66.6, CH

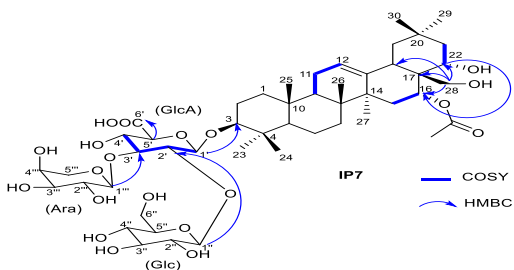

Figure 3.56. COSY and HMBC correlations of compound Iparvisepala-1 (**IP7**)

Basing on above-mentioned spectrum data analysis, structure of compound **IP7** was identified as 3-*O*-{[α -L-arabinopyranosyl-(1-3)]- β -D-glucopyranosyl-(1-2)}- β -D-glucuronopyranoside 16 α -*O*-acetyl-3 β ,22 α ,28 β -trihydroxy-olean-12-ene (named Iparvisepala-1). The structure of **IP7** was almost identical to those of saponin 3-*O*-{[β -D-glucopyranosyl-(1-3)]- β -D-glucuronopyranoside 16-*O*-acetyl-3 β ,22 α ,28 β -trihydroxy-olean-12-ene (named IPS-1) with only one difference of the sugar unit connected to C-3' of glucuronopyranose (**Figure 3.57**, **Table 3.25**).

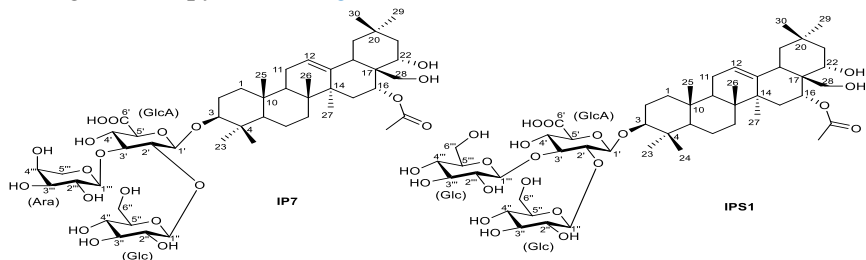

Figure 3.2. Structure of compounds **IP7** and **IPS1**

Table 3.25. ^1H - and ^{13}C -NMR data of compound **IP7** as compared to that of **IPS1** published in literature

C	Compound IP7 (CD_3OD)		IPS1 (CD_3OD : D_2O (95:5))	
	δ_{H}	δ_{C}	δ_{H}	δ_{C}
1	1.02 (m) 1.63 (m)	39.9, CH_2	1.00/1.64	41.3, CH_2
2	2.01 (m)	27.4, CH_2	1.74/1.96	28.2, CH_2

	1.73 (m)			
3	3.23 (dd, $J = 4.2, 12.0$ Hz)	91.8, CH	3.22 (dd, $J = 5.4, 13.3$ Hz)	93.4, CH
4	-	41.1, C	-	41.8, C
5	0.80 (d, $J = 12.0$ Hz)	56.9, CH	0.78 (d, $J = 11.9$ Hz)	58.3, CH
6	1.57 (m) 1.40 (m)	19.2, CH ₂	1.56/1.42	20.5, CH ₂
7	1.57 (m) 1.35 (m)	33.9, CH ₂	1.57/1.35	35.2, CH ₂
8	-	40.5, C	-	42.4, C
9	1.68 (m)	48.0, CH	1.65	49.3, CH
10	-	37.8 C	-	39.1, C
11	1.91 (m)	24.5, CH ₂	1.92	25.8, CH ₂
12	5.37 (t, $J = 3.6$ Hz)	125.3, CH	5.35 (t, $J = 3.6$ Hz)	126.6, CH
13	-	142.6, C	-	143.6, C
14	-	42.8, C	-	43.8, C
15	1.51 (m) 1.95 (m)	31.5, CH ₂	1.48/1.95	32.9, CH ₂
16	5.48 (m)	72.7, CH	5.47 (m)	74.3, CH
17	-	44.4, C	-	45.7, C
18	2.20 (dd, $J = 3.6, 13.8$ Hz)	42.5, CH	2.20 (dd, $J = 3.53, 14.0$ Hz)	44.0, CH
19	2.25 (m) 1.13 (m)	48.0, CH ₂	2.26/1.11	49.4, CH ₂
20	-	32.2, C	-	33.4, C
21	1.48 (m) 1.7 (m)	45.0, CH ₂	1.48/1.66	46.3, CH ₂
22	4.07 (dd, $J = 5.5, 12.0$ Hz)	73.9, CH	4.06 (dd, $J = 5.6, 12.13$ Hz)	75.2, CH
23	1.09 (s)	28.2, CH ₃	1.07 (s)	29.6, CH ₃
24	0.89 (s)	16.9, CH ₃	0.89 (s)	18.3, CH ₃
25	1.00 (s)	16.2, CH ₃	0.98 (s)	17.4, CH ₃
26	1.01 (s)	17.3, CH ₃	0.96 (s)	18.6, CH ₃
27	1.34 (s)	27.4, CH ₃	1.31 (s)	28.7, CH ₃
28	3.30 (m) 3.60 (m)	69.8, CH ₂	3.30/3.60	71.3, CH ₂
29	0.98 (s)	33.9, CH ₃	0.96 (s)	35.2, CH ₃
30	1.01 (s)	25.4, CH ₃	0.99 (s)	26.7, CH ₃
CH ₃ COO	-	171.8, C	-	173.9, C

$\underline{\text{CH}_3\text{COO}}$	2.03 (s)	22.2, CH_3	-	23.6, CH_3
3-OGlcA			3-OGlcA	
1'	4.48 (d, $J = 7.8$ Hz)	105.7, CH	4.50 (d, $J = 7.2$ Hz)	106.7, CH
2'	3.82 (m)	78.8, CH	3.85 (m)	80.0, CH
3'	3.77 (t, $J = 8.4$)	86.3, CH	3.84 (m)	87.7, CH
4'	3.64 (m)	72.9, CH	3.65 (m)	73.7, CH
5'	3.62 (m)	78.3, CH	3.65 (m)	79.3, CH
6'	-	176.1, C	-	-
2'-OGlc			2'-OGlc	
1''	4.98 (d, $J = 7.8$ Hz)	103.2, CH	4.98 (d, $J = 7.8$ Hz)	104.4, CH
2''	3.19 (m)	76.2, CH	3.21	77.4, CH
3''	3.37 (m)	78.2, CH	3.42	79.3, CH
4''	3.10 (m)	72.6, CH	3.15	73.7, CH
5''	3.37 (m)	78.2, CH	3.34	79.5, CH
6''	3.57 (dd, $J = 7.2, 12.0$ Hz) 3.84 (dd, $J = 1.8, 10.2$ Hz)	63.6, CH_2	3.59 3.86	64.7, CH_2
3'-OAra			3'-OGlc	
1'''	4.64 (d, $J = 7.2$ Hz)	104.7, CH	4.77 (d, $J = 7.8$ Hz)	105.1, CH
2'''	3.62 (m)	72.1, CH	3.32	76.7, CH
3'''	3.57 (m)	74.6, CH	3.42	79.3, CH
4'''	3.80 (m)	70.1, CH	3.38	72.8, CH
5'''	3.94 (dd, $J = 2.4, 12.6$ Hz) 3.61 (m)	67.7, CH_2	3.34	79.5, CH
6'''	-	-	3.69/3.89	63.7, CH_2

3.2. Results on biological evaluation

3.2.1. Anti-inflammatory activity

The results of anti-inflammatory assay illustrated that compound **IC9** weakly inhibited NO production with the IC_{50} value of 704.23 ± 42.92 μM . The positive control, L-NMMA, had an IC_{50} value of 27.75 ± 1.61 μM . Whereas, the other four compounds (**IC5**, **IC7**, **IC10**, and **IC15**) showed no inhibitory effect on NO production at the tested concentrations 200, 100, 20, 4, and 0.8 $\mu\text{g/mL}$ ($\text{IC}_{50} > 200$ ($\mu\text{g/mL}$)) (Table 3.30).

Table 3.30. NO inhibitory activities of compounds isolated from *I. chapaensis*

Tested compounds	IC ₅₀
IC5	>200 (µg/mL)
IC7	>200 (µg/mL)
IC9	107.15 ± 6.53 (µg/mL) (704.23 ± 42.92 µM)
IC10	>200 (µg/mL)
IC15	>200 (µg/mL)
L-NMMA	6.89 ± 0.40 (µg/mL) (27.75 ± 1.61 µM)

3.2.1. Hypoglycemic activity

❖ *I. chapaensis*

The results showed that flavanone **IC5** was indicated as the most potent α -glucosidase inhibitor with the IC₅₀ value of 101.38 ± 8.96 µM, as compared to positive control acarbose (IC₅₀ 227.14 ± 13.71 µM). Besides, compound **IC14** weakly suppressed on tested enzyme (IC₅₀ = 1656.5 ± 39.68 µM). None of the remaining five tested compounds (**IC7**, **IC9**, **IC10**, **IC15**, and **IC16**) showed any inhibitory activity, regardless of investigated concentrations 4, 20, 100, and 500 µg/mL (IC₅₀ > 500 (µg/mL) (Table 3.30).

Table 3.2. α -Glucosidase inhibitory activities of compounds isolated from *I. chapaensis* species

Tested compounds	IC ₅₀
IC5	28.91 ± 2.58 (µg/mL) (101.38 ± 8.96 µM)
IC7	>500 (µg/mL)
IC9	>500 (µg/mL)
IC10	>500 (µg/mL)
IC14	367.74 ± 8.81 (µg/mL) (1656.5 ± 39.68 µM)
IC15	>500 (µg/mL)
IC16	>500 (µg/mL)
Acarbose	146.64 ± 8.85 (µg/mL) (227.14 ± 13.71 µM)

❖ *I. parvisepala*

In vitro evaluation of the α -glucosidase inhibitory potential was carried out on three isolated metabolites (**IP2**, **IP8**, and **IP10**) to result the most suppressor effect of apigenin-7-*O*-glucoside (**IP2**) on the tested enzyme ($IC_{50} = 12.53 \pm 0.39 \mu\text{M}$), which was significantly better than that observed for the positive control, acarbose ($IC_{50} = 197.53 \pm 2.68 \mu\text{M}$). Meanwhile, 2 compounds (**IP8** and **IP10**) failed to inhibit the tested enzyme at the studied concentrations 4, 20, 100, and 500 $\mu\text{g/mL}$ ($IC_{50} > 500 \mu\text{g/mL}$) (Table 3.32).

Table 3.3. α -Glucosidase inhibition effect of compounds isolated from *I. parvisepala*

Tested compounds	IC_{50}
IP2	$5.42 \pm 0.17 \mu\text{g/mL}$ ($12.53 \pm 0.39 \mu\text{M}$)
IP8	$> 500 \mu\text{g/mL}$
IP10	$> 500 \mu\text{g/mL}$
Acarbose	$127.53 \pm 1.73 \mu\text{g/mL}$ ($197.53 \pm 2.68 \mu\text{M}$)

❖ **New compound: Iparvisepala-1 (IP7)**

New triterpene saponin iparvisepala-1 (**IP7**) was tested for hypoglycemic activity via α -glucosidase inhibition effect using acarbose as a positive control. However, **IP7** was found to be insensitive to the tested enzyme at the investigated concentrations 0.39, 1.56, 6.25, 25, and 100 $\mu\text{g/mL}$ ($IC_{50} > 100 \mu\text{g/mL}$) (Table 3.33).

Table 3.4. α -Glucosidase inhibitory effect of new compound Iparvisepala-1 (**IP7**)

Compounds	IC_{50}
IP7	$> 100 \mu\text{g/mL}$
Acarbose	$134.56 \pm 3.02 \mu\text{g/mL}$ ($208.74 \pm 4.67 \mu\text{M}$)

CONCLUSION AND RECOMMENDATION

1. Study on chemical constituents of two *Impatiens* species (*I. chapaensis* and *I. parvisepala*)

27 compounds were isolated and structurely elucidated from two investigated species. Among these, compound Iparvisepala-1 (**IP7**) was new to science, while 16 compounds were found for the first time from *Impatiens* genus, as follows:

- 16 compounds (**IC1 – IC16**) were purified and structure elucidated from *I. chapaensis*, including 8 flavonoids: (*S*)-naringenin (**IC1**), (*S*)-pinocembrin (**IC2**), kaempferol (**IC3**), quercetin (**IC4**), (\pm)-3',5',5,7-tetrahydroxyflavanone (**IC5**), phlorizin (**IC6**), 2,4-dihydroxydihydrochalcone-6-*O*- β -D-glucopyranoside (**IC7**), and isoquercitrin (**IC8**); 3 monophenols: methyl 4-hydroxybenzoate (**IC9**), methyl 2,4,6-trihydroxybenzoate (**IC10**), and isotachioside (**IC11**); and 5 miscellaneous: uridine (**IC12**), spinasterol (**IC13**), isofraxidin (**IC14**), (7*R*,8*S*)-yemuoside YM1 (**IC15**), and (*S*)-dehydrovomifoliol (**IC16**). Among these, 9 compounds (**IC1**, **IC5**, **IC6**, **IC7**, **IC10**, **IC11**, **IC12**, **IC15**, and **IC16**) were isolated for the first time from *Impatiens* genus.

- 11 compounds (**IP1 – IP11**) were isolated and structure determined from *I. parvisepala*, including 4 flavonoids: kaempferol-3-*O*- α -L-rhamnopyranosyl-(1 \rightarrow 6)- β -D-glucopyranoside (**IP1**), apigenin 7-*O*- β -D-glucopyranoside (**IP2**), isoquercitrin (**IP3**), and phlorizin (**IP4**); 3 triterpenoids: lupeol (**IP5**), ginsenoside Rg1 (**IP6**), and iparvisepala-1 (**IP7**); and 4 miscellaneous: α -tocopherylquinone (**IP8**), phytol (**IP9**), 1-[nonadeca-(9*Z*,12*Z*)-dienoyl]-*sn*-glycerol (**IP10**), and uracil (**IP11**). Among these, compound **IP7** was found as a new triterpene saponin, while 7 compounds kaempferol-3-*O*- α -L-rhamnopyranosyl-(1 \rightarrow 6)- β -D-glucopyranoside (**IP1**, **IP5**, **IP6**, **IP8**, **IP9**, **IP10**, and **IP11**) were the first representatives of the genus *Impatiens*.

2. Evaluation on anti-inflammatory and hypoglycemic activities of two *Impatiens* species

5 isolates (**IC5**, **IC7**, **IC9**, **IC10**, and **IC15**) were investigated for anti-inflammatory activity through the inhibition effect on NO production. The results showed that methyl 4-hydroxybenzoate (**IC9**) weakly inhibited NO production with the IC_{50} value of 704.23 ± 42.92 μ M, as compared to standard compound L-NMMA ($IC_{50} = 27.75 \pm 1.61$ μ M).

Out of 11 compounds (**IC5**, **IC7**, **IC9**, **IC10**, **IC14**, **IC15**, **IC16**, **IP2**, **IP7**, **IP8**, and **IP10**) isolated from two investigated species, 2 flavonoids (\pm)-3',5',5,7-tetrahydroxyflavanone (**IC5**) and apigenin 7-*O*- β -D-glucopyranoside (**IP2**) showed strong effect on α -glucosidase inhibition with the respective IC_{50} of 101.38 ± 8.96 μ M and $IC_{50} = 12.53 \pm 0.39$ μ M, much better than that observed for positive compound acarbose ($IC_{50} = 197.53 \pm 2.68$ μ M).

➤ Recommendation

1. Continue to study on phytochemistry of some *Impatiens* species growing in Vietnam and search for anti-inflammatory and hypoglycemic compounds from these sources.
2. The results on biological investigations showed the potential inhibitory effect of 2 flavonoids **IC5** and **IP2** on α -glucosidase, therefore, further studies need to be done to use these metabolites in the field of health protection.

NEW CONTRIBUTIONS OF THE THESIS

- For the first time two species *I. chapaensis* and *I. parvisepala* were studied on chemical constituents: 27 compounds were purified and structurally determined. Among these, one compound Iparvisepala-1 (**IP7**) was new and 16 compounds were firstly isolated from *Impatiens* genus.
- For the first time 5 compounds (**IC5**, **IC7**, **IC9**, **IC10**, and **IC15**) isolated from *I. chapaensis* was evaluated on anti-inflammatory activity: compound methyl 4-hydroxybenzoate (**IC9**) indicated weak effect on inhibition of NO production.
- For the first time 7 compounds (**IC5**, **IC7**, **IC9**, **IC10**, and **IC14-IC16**) isolated from *I. chapaensis* and 4 compounds (**IP2**, **IP7**, **IP8**, and **IP10**) isolated from *I. parvisepala* were evaluated on hypoglycemic activity: 2 flavonoids, including (\pm)-3',5',5,7-tetrahydroxyflavanone (**IC5**) and apigenin 7-*O*- β -D-glucopyranoside (**IP2**) showed promising activity against α -glucosidase, which were much better than that obtained for positive control acarbose.

LIST OF PUBLISHED ARTICLES

1. **Nguyen Thi Thuy Linh**, Trinh Thi Thuy, Nguyen Thanh Tam, Ba Thi Cham, Khieu Thi Tam, Nguyen Hoang Sa, Do Thi Thao, Vu Tien Chinh, Nguyen Thi Hoang Anh. *Chemical constituents of Impatiens chapaensis Tard. and their α -glucosidase inhibition activities*, Natural product research, 2021, 36 (12), 3229-3233. Doi: 10.1080/14786419.2021.1956923.
2. **Nguyen Thi Thuy Linh**, Trinh Thi Thuy, Nguyen Thanh Tam, Ba Thi Cham, Bui Huu Tai, Do Thi Thao, Dinh Gia Thien, Vu Tien Chinh, Nguyen Thi Hoang Anh. *Chemical constituents of Impatiens parvisepala and their α -glucosidase inhibition activity*, Natural product research, 2022. Doi: 10.1080/14786419.2022.2127705.